

MOCVO crystal oscillator kit

This crystal oscillator kit is part of a range of kits from MOCVO that can be used alone or to assist in an Intermediate amateur radio licence training program.

Assembly

As you can see from **Photo 1**, the kit is supplied with all the component parts along with a small printed circuit board (PCB). In addition to the hardware, there were 3 pages of A4 size instructions that included the PCB layout and a photograph of the finished kit. I was surprised that there was no circuit diagram in the assembly notes as I would have thought that would aid the learning process.

Assembly of the kit was straightforward and the step-by-step instructions were very clear. The assembly followed the usual practice of mounting the resistors and capacitors first. The convention of assembling resistors and capacitors first comes from the premise that passive components are cheaper and generally more robust so can tolerate more heat and mechanical stress. If you are planning to use the kit as part of a project, rather than a learning exercise, it would be advisable to drill a couple of mounting holes in the PCB before you start assembly.

Assembly continued by installing the wire-ended crystal and the 2N3904 NPN transistor. The final steps were to solder the PP-3 battery connector, Molex output connector and the polyvaricon variable capacitor. I've shown a photo of the completed kit in **Photo 2**.

Circuit design

I traced-out the circuit diagram of the oscillator and have shown this in **Figure 1**. Those of you familiar with home construction will recognise this as a classic Colpitts design but with a varicon variable capacitor in series with the ground leg of the crystal. This latter feature enables the oscillator to be pulled from its nominal frequency thus producing a Variable Crystal Oscillator (VXO). This technique is useful because the crystal accurately defines the centre frequency of the oscillator, whilst the series variable capacitor enables a tuning range of a few kHz either side of this frequency.

The Colpitts design was originally developed by American engineer Edwin H Colpitts back in 1918 and is one of a number

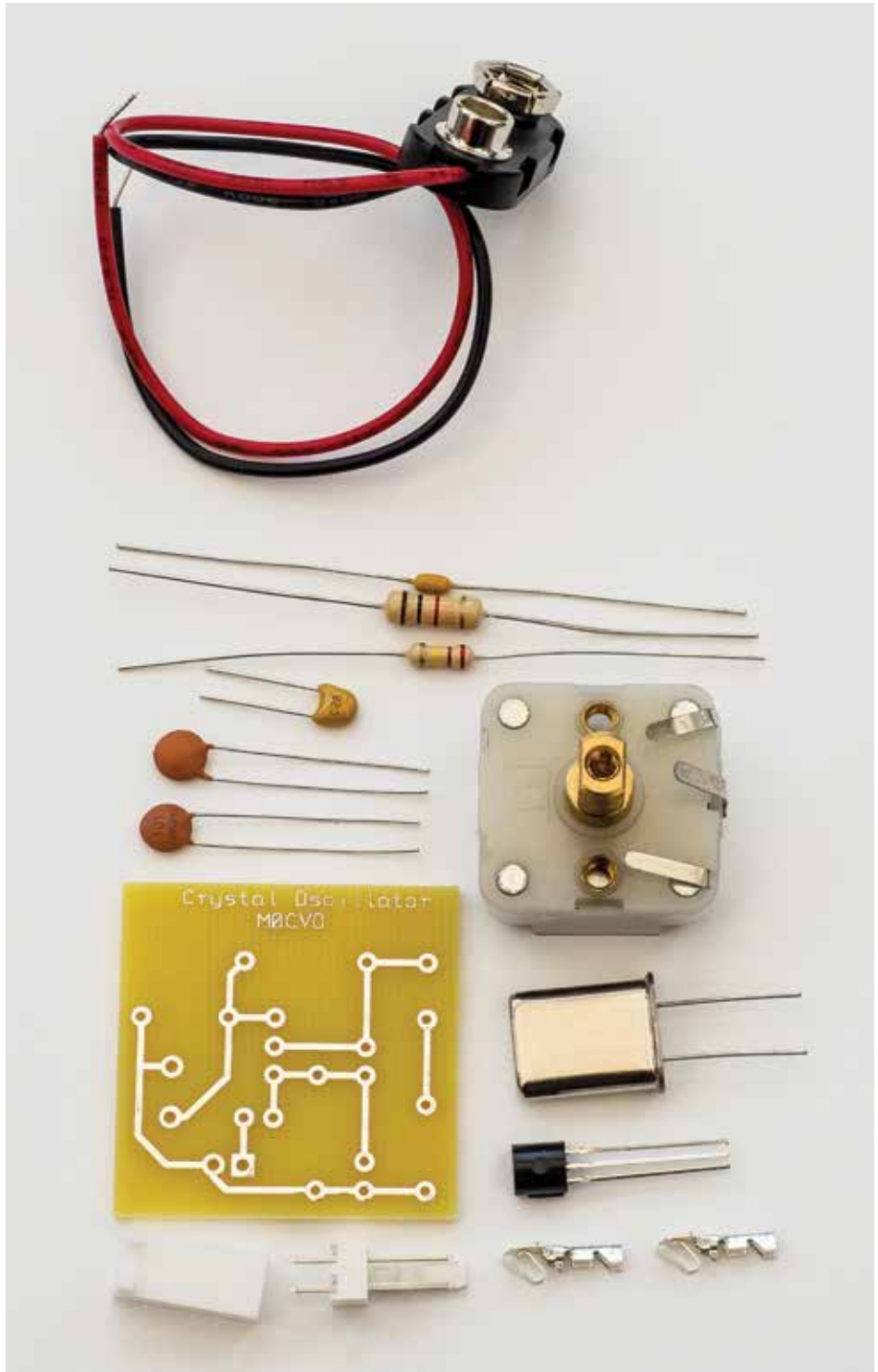

PHOTO 1: MOCVO oscillator kit parts.

Continued on page 70

Mike Franklin, G3VYI
mike.franklin3@btinternet.com

the tone frequency link selectable over eight values; only the 1600Hz option is used here. Another link swaps the polarity of the I/Q drive signals for LSB/USB selection or, more to the point, helps in later setting up to save having to swap channels. (Murphy's Law says you'll always get I/Q the wrong way round the first time such a circuit is tested). PIC code for the LO source can be found at [6].

One shortcoming in the circuit as shown is that there is no low pass filtering of the audio input. In practice there really should be some cutoff of audio input frequencies above 3.5kHz. With the mixer driven by a square wave it will respond to all odd order harmonics of the LO, so frequencies within 1.3kHz either side of 4.8kHz (the third harmonic) will also be mixed into the output passband. As will those around 8kHz, and so on. My excuses for not including such filtering are: a) for voice this module will be driven from a separate VOGAD amplifier (see Design Notes April 2013) so any filtering can be included on that; b) it is more likely to be used with the soundcard output from a PC generating data modes than it will real voice. In which case the soundcard will deliver a clean waveform to start with; and c), I just plain forgot.

Photo 1 shows my version on a PCB,

driving a U2793 quadrature upconverter for use at 30 to 300MHz. A slightly different version, configured as an LF converter for narrowband data modes will be described in more detail in a forthcoming *RadCom Plus*.

DSP Implementation – a challenge

I can hear it now – “Why do this with lots of analogue hardware when a DSP chip will be simpler, cheaper and better?”. Yes, a DSPIC can do everything, right from input filtering all the way through to analogue output from its D/A converters, and with very little additional hardware than the chip itself. But I can't program DSPICs (don't ask) and for some reason no one else seems to offer a ready-to-go I/Q generator program to blow into one, in spite of the simplicity of the task.

So here is the challenge: who will be the first to produce a publicly available Third Method (or phasing type, or both) SSB generator. All we need is a simple .HEX file for blowing directly into a DSPIC; nothing complicated, just plug-n-play for anyone with a PIC programmer.

It's not a mistake

The eagle-eyed may notice something a bit 'odd' about the circuit diagram of Figure 2.

All will be revealed next time.

Websearch

- [1] www.linear.com/product/LTC4365
- [2] www.ti.com/product/tps25921a
- [3] www.onsemi.com/pub_link/Collateral/NCP361-D.PDF
- [4] Generating the 0° and 90° at RF is straightforward, in comparison. Digital dividers fed at 4 * LO can supply a perfect quadrature output over an enormously wide frequency range. Accurate passive networks can be made for a narrow bandwidth. There are whole families of dedicated quadrature upconverter chips. Several of these were covered in the February 2012 edition of this column.
- [5] An instructive way to see the process is to view the two I/Q mixer outputs on a dual trace scope while applying a variable single tone to the input. As the input frequency is swept up from 300Hz the trace will show two sine waves, separated by 90°, whose frequency drops as the input approaches 1600Hz. As the frequency is raised further, the traces show a now-increasing frequency, but with their relative phase swapped over. Or has one swapped its polarity?
- [6] www.g4jnt.com/QuadAudioLO.zip – this contains firmware for the quadrature tone generator. A fully documented assembler listing is included so constructors can modify it at will to use other tone or crystal frequencies

MOCVO crystal oscillator kit – continued from page 55

of standard oscillator designs that have stood the test of time. The key feature of a Colpitts oscillator is the use of a capacitive tap to supply the feedback signal for the oscillator. The design employed in the MOCVO kit is a standard emitter follower or common collector amplifier with the capacitive tap formed by C2 and C3 and R1 supplying the base bias voltage. R2, set at 1k, provides a relatively low output impedance (approx. 150R) for driving the following stages.

I also took the opportunity to take a closer look at the output waveform, which was roughly sinusoidal at 7.03MHz but the output is also rich in harmonics. Examination with a spectrum analyser revealed the following useful harmonics: 14.06MHz (-10dB), 21.09MHz (-17dB) and 28.12MHz (-26dB). Whilst these harmonics are useful for accessing other bands, you will need some good filtering to tame these when using the oscillator as the basis of a 7.03MHz CW QRP transmitter.



PHOTO 2: The completed MOCVO oscillator kit

Kit testing

The kit instructions recommend testing with a receiver set to USB and tuned to the nominal frequency of the crystal. As the review model was for 40m it was supplied with a 7.030MHz crystal, which is conveniently the QRP CW calling frequency. After powering-up with a 9V PP3 battery, I tuned to the 7.030MHz crystal frequency and swung the capacitor until I heard a tone. I was then able to track the capacitor tuning range by following the tone to its LF and HF limits and tuning the receiver until the tone frequency decreased to close to zero (zero-beat). This produced a measured tuning range of 7.0285MHz to 7.0313MHz, which was a total span of 2.8kHz. This was a very useful tuning range and fine for its intended use as the oscillator in a simple QRP CW transmitter.

Summary

The MOCVO oscillator kit is a useful and simple to build project that would indeed be useful as part of an Intermediate licence training program. The kit costs £7.00 and is available direct from

MOCVO Antennas (m0cvoantennas.webs.com). Versions are currently available for 7.03MHz and 14.06MHz. My thanks to MOCVO Antennas for supplying the review kit.

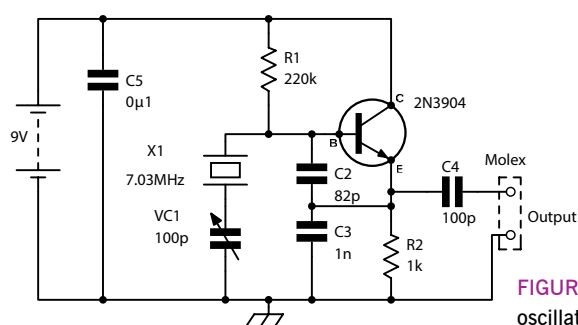

FIGURE 1: MOCVO oscillator circuit diagram